

# 大同大學101 學年度(寒)轉學入學考試試題

考試科目：電路學

所別：電機工程學系

第 全 頁

註：本次考試 不可以參考自己的書籍及筆記； 不可以使用字典； 不可以使用計算器。

(1) Calculate  $V_o$  and  $I_o$  in the circuit of Fig.1.

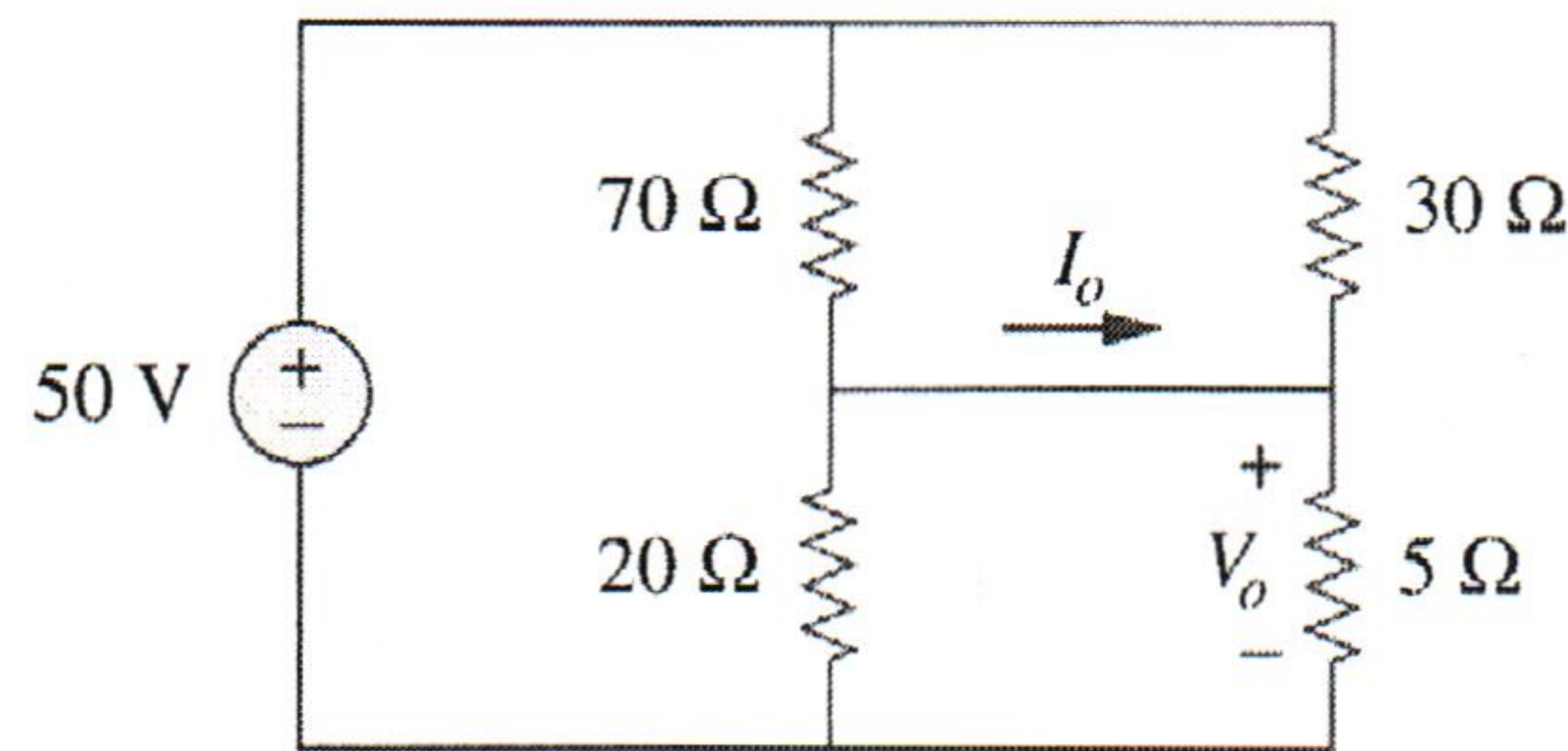

Fig.1

(2) Determine the node voltages  $V_1$ ,  $V_2$ , and  $V_3$  in the circuit in Fig. 2.

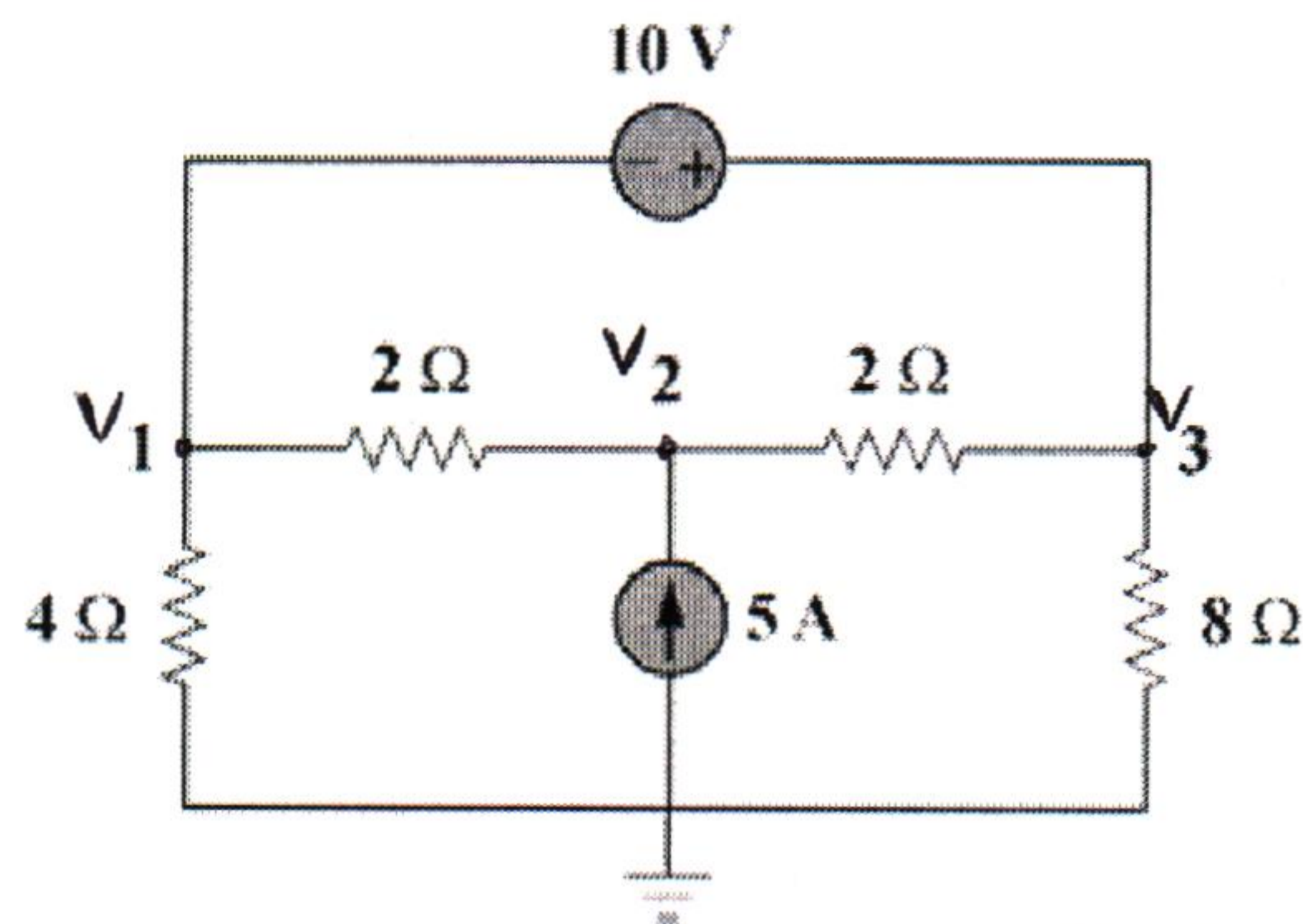

Fig.2

(3) For the transistor model in Fig. 3, obtain the Thevenin equivalent at terminals  $a-b$ .

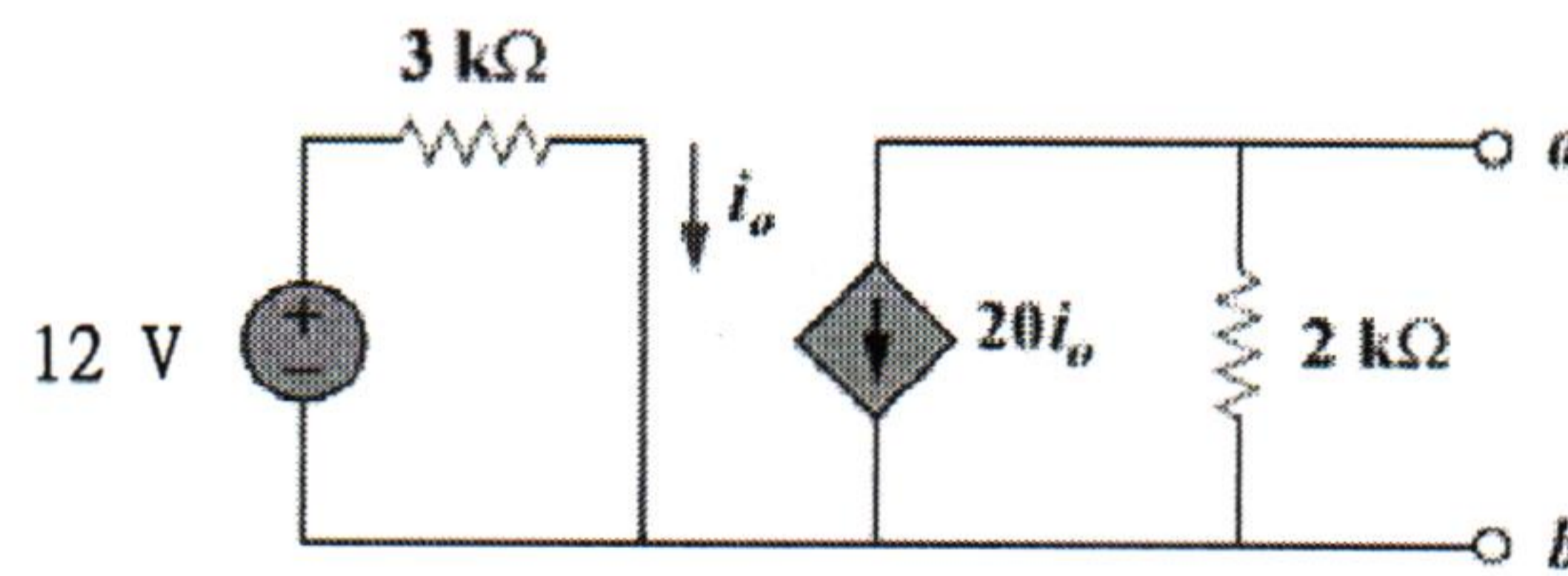

Fig. 3.

(4) For the circuit in Fig. 4, determine:  
 (a) the voltage across each capacitor,  
 (b) the energy stored in each capacitor.

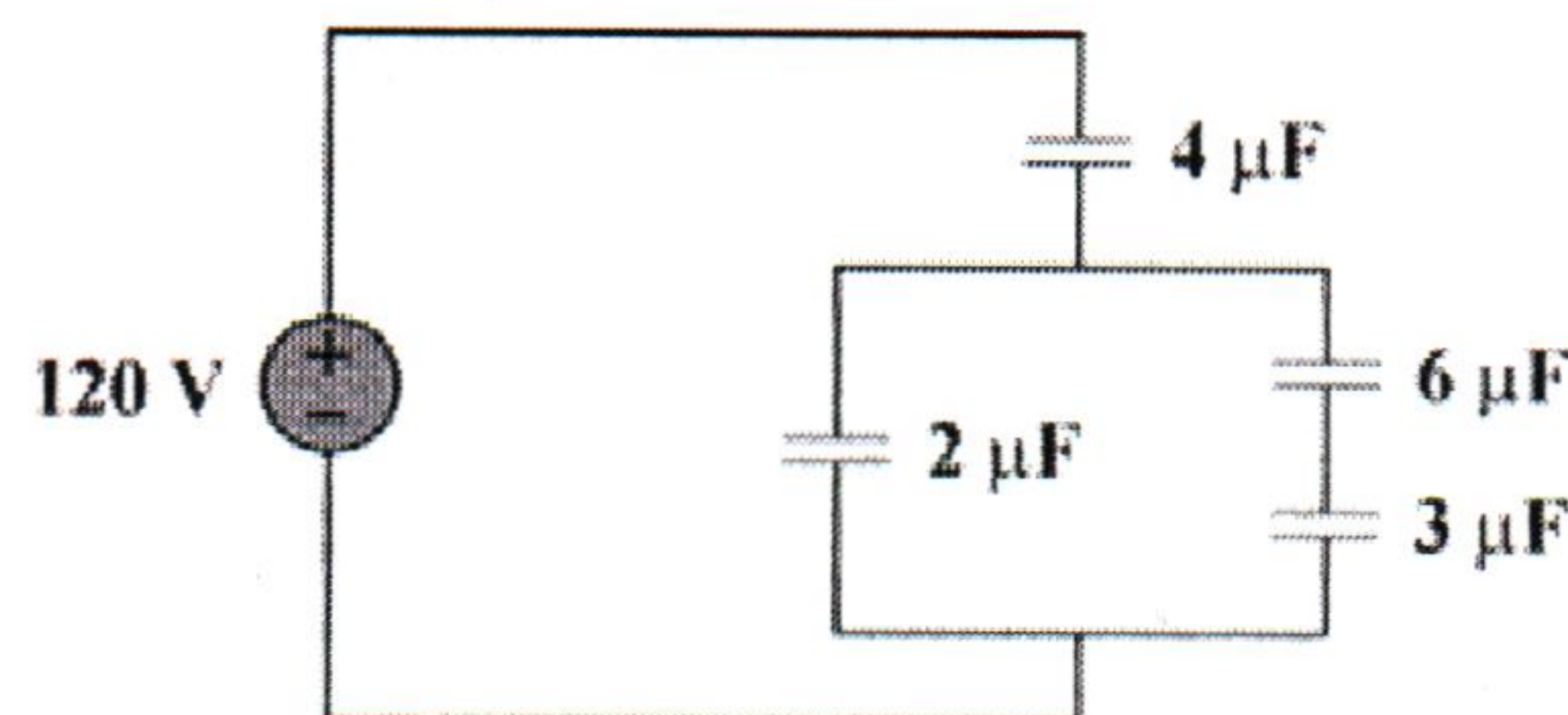

Fig. 4.